



# D8T Tessmann Edition Pro Sheet

Driver Ty Tessmann

Date May 2/3 2015

Track Thunder Alley

Event Battle of the SIKest

Track Condition Wet, Big jumps, Smooth, Tight.

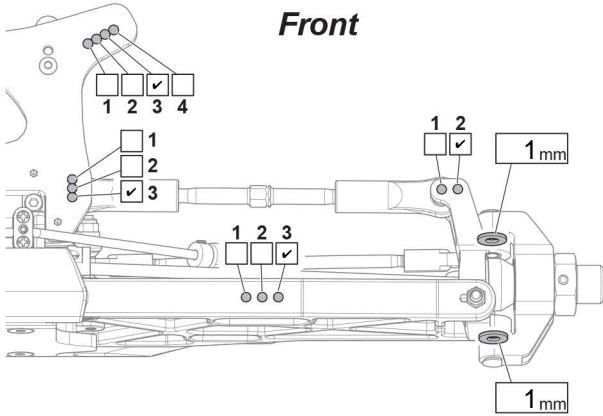

Front

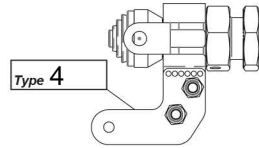

Type 4

Body Brand  
**Proline**

Body Model  
**Enforcer**

Ride Height 37 mm

Camber Angle .5°

Toe Angle .5 out°

Sway Bar 2.4 mm

Shock Length 114 mm

Front Shocks	
Oil weight	Losi 35 wt
Piston	6x1.3 mm
Bladder	Stock
Spring	HB Gold

Notes 18mm rebound in shock

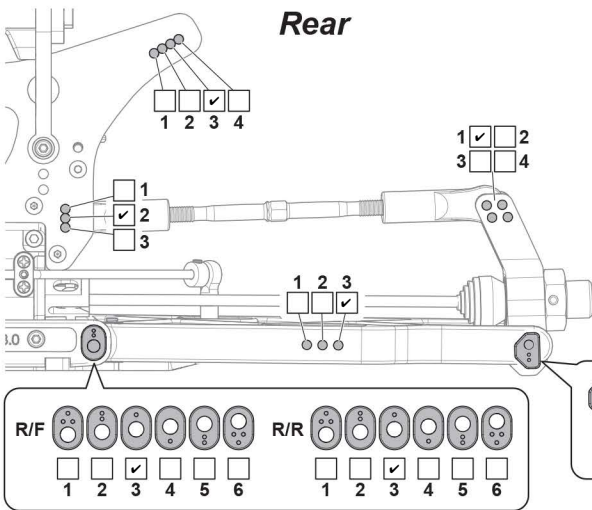

Rear

Wing Brand  
**Proline**

Wing Model  
**Lexan Trifecta**

Ride Height 40 mm

Camber Angle .5°

Sway Bar 2.8 mm

Shock Length 124 mm

Rear Shocks	
Oil weight	Losi 32.5 wt
Piston	6x1.3 mm
Bladder	Stock
Spring	HB Orange

Notes 20mm rebound

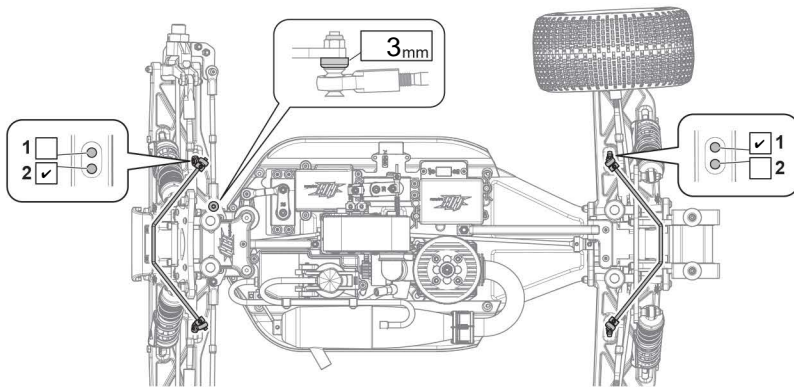

Engine	
Brand	O.S.
Spur gear	Clutch Bell
50	13
Clutch Shoes	2 carbon / 1 alum
Clutch Springs	stock
Glow Plug	P3
Glow Fuel	

Tires	Front	Rear
Brand	Proline	Holeshot
Compound	X3	X3
Insert	Closed	Cell
Wheel	PL	PL
Notes		

Notes Track was very technical and tight, added rear brake

Diff Oils	Front	Center	Rear
	Brand	Losi	Losi
Oil Weight / Grade	7K	10K	3K